

- Hunt, J. B., Smyrniotis, P. Z., Ginzburg, A., & Stadtman, E. R. (1975) *Arch. Biochem. Biophys.* 166, 102-124.
- Jaffe, E. K., & Cohn, M. (1978) *J. Biol. Chem.* 253, 4823-4825.
- Jarvest, R. L., Lowe, G., & Potter, B. V. L. (1981) *J. Chem. Soc., Perkin Trans. 1*, 3186-3195.
- Knowles, J. R. (1980) *Annu. Rev. Biochem.* 49, 877-919.
- Ratner, S. (1973) *Adv. Enzymol. Relat. Areas Mol. Biol.* 39, 1-91.
- Raushel, F. M., & Seiglie, J. L. (1983) *Arch. Biochem. Biophys.* 225, 979-985.
- Raushel, F. M., Rawding, C. J., Anderson, P. M., & Villafanra, J. J. (1979) *Biochemistry* 18, 5562-5566.
- Richard, J. P., & Frey, P. A. (1982) *J. Am. Chem. Soc.* 104, 3476-3481.
- Rochovansky, O., Kodowki, H., & Ratner, S. (1977) *J. Biol. Chem.* 252, 5287-5294.
- Sheu, K. F., & Frey, P. A. (1977) *J. Biol. Chem.* 252, 4445-4448.
- Tsai, M.-D. (1979) *Biochemistry* 18, 1468-1472.
- Walsh, C. T. (1978) in *Enzymatic Reaction Mechanisms*, pp 210-239, W. H. Freeman, San Francisco.

Isotopic Probes of the Argininosuccinate Lyase Reaction[†]

Sung Chun Kim and Frank M. Raushel*

Departments of Chemistry and Biochemistry, Texas A&M University, College Station, Texas 77843

Received March 12, 1986; Revised Manuscript Received April 23, 1986

ABSTRACT: The mechanism of the argininosuccinate lyase reaction has been probed by the measurement of the effects of isotopic substitution at the reaction centers. A primary deuterium isotope effect of 1.0 on both V and V/K is obtained with (2*S*,3*R*)-argininosuccinate-3-*d*, while a primary ¹⁵N isotope effect on V/K of 0.9964 ± 0.0003 is observed. The ¹⁵N isotope effect on the equilibrium constant is 1.018 ± 0.001 . The proton that is abstracted from C-3 of argininosuccinate is unable to exchange with the solvent from the enzyme-intermediate complex but is rapidly exchanged with solvent from the enzyme-fumarate-arginine complex. A deuterium solvent isotope effect of 2.0 is observed on the V_{\max} of the forward reaction. These and other data have been interpreted to suggest that argininosuccinate lyase catalyzes the cleavage of argininosuccinate via a carbanion intermediate. The proton abstraction step is not rate limiting, but the inverse ¹⁵N primary isotope effect and the solvent deuterium isotope effect suggest that protonation of the guanidino group and carbon-nitrogen bond cleavage of argininosuccinate are kinetically significant.

Argininosuccinate lyase catalyzes the cleavage of argininosuccinate to arginine and fumarate. The enzyme is found in the liver where it functions in the biosynthesis of urea. The enzyme from bovine liver has been shown by Lusty and Ratner (1972) to be a tetramer of four identical subunits. No external cofactor is involved, and the enzyme apparently does not require metal ions for catalytic activity.

The details of the catalytic events leading to the chemical transformation of argininosuccinate to fumarate and arginine are largely unknown. Ratner and co-workers have shown that the reaction involves the trans elimination of arginine and the *pro-R* hydrogen at C-3 of argininosuccinate (Hoberman et al., 1965). The kinetic mechanism of the reaction is random (Raushel & Nygaard, 1983), but the release of fumarate from the enzyme-arginine-fumarate complex is at least 10 times faster than the release of arginine (Raushel & Garrard, 1984; Kim & Raushel, 1986). There appears to be a carboxylate group and a histidine residue at the active site of the enzyme that can function as a general base and a general acid in the abstraction of a proton from C-3 and the donation of a proton to the departing arginine (Garrard et al., 1985).

In this paper we report on our efforts to determine the magnitude and the timing of the bond-breaking steps in the conversion of argininosuccinate to arginine and fumarate. The

Chart I

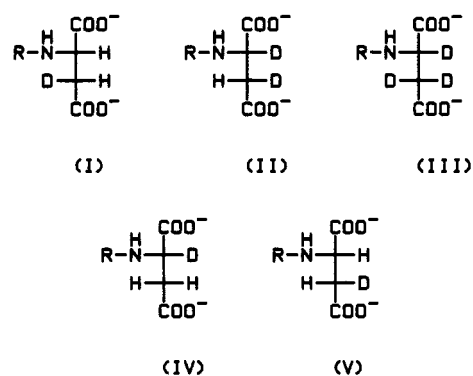

chemical mechanism appears to involve the initial formation of a carbanion intermediate. This proposal is based primarily on the tight binding of the nitro analogue of argininosuccinate (Raushel, 1984) and the enzymatic formation of 2-fluoro-argininosuccinate from fluorofumarate (Garrard et al., 1983). The details of the chemical reaction have now been further probed by analyzing the effects of isotopic substitution at the reaction centers.

MATERIALS AND METHODS

Arginase, urease, aspartate aminotransferase, inorganic pyrophosphatase, and glutamate dehydrogenase were purchased from Sigma Chemical Co. Argininosuccinate lyase

[†] This research has been supported by the National Institutes of Health (AM-30343) and the Robert A. Welch Foundation (A-840). F.M.R. is the recipient of NIH Research Career Development Award AM-01366.

was isolated from bovine liver according to the procedure of Havir et al. (1965) and Schultze et al. (1970). Argininosuccinate synthetase was isolated from bovine liver according to the slightly modified method of Rochovansky et al. (1977). Fumarate-2,3-*d*₂ (98 atom %) was purchased from Merck. All of the other chemicals were purchased from either Sigma or Aldrich.

Synthesis of (2S,3R)-Argininosuccinate-3-d (I), (2S,3S)-Argininosuccinate-2,3-d₂ (II), and (2S)-Argininosuccinate-2,3,3-d₃ (III) (Chart I). (2S,3R)-Argininosuccinate-3-*d* was made enzymatically by the reverse reaction of argininosuccinate lyase (Ratner et al., 1953) in the presence of D₂O. The reaction mixture contained 100 mM phosphate buffer, pD 7.5, 150 mM arginine, 100 mM fumarate, and 2 units of argininosuccinate lyase in a volume of 50 mL. The time course of the reaction was monitored by following the decrease in the concentration of fumarate at 240 nm. The reaction was terminated after 24 h of incubation by the addition of 20 mL of 50% trichloroacetic acid. The (2S,3R)-argininosuccinate-3-*d* was isolated as the barium salt as described by Ratner et al. (1953). The 200-MHz proton NMR spectrum for (2S,3R)-argininosuccinate-3-*d* showed that the incorporation of deuterium at C-3 was 91%. The overall yield was 65%. The synthesis of (2S,3S)-argininosuccinate-2,3-*d*₂ was accomplished by a similar procedure except that fumarate-2,3-*d*₂ and H₂O were used as substrates. The incorporation of deuterium at C-2 and C-3 was 92% from an analysis of the proton NMR spectrum. (2S)-Argininosuccinate-2,3,3-*d*₃ was synthesized enzymatically from arginine, fumarate-2,3-*d*₂, and D₂O by the action of argininosuccinate lyase. NMR analysis indicated that the incorporation of deuterium was 98, 98, and 90% at C-2, C-3 *pro-S*, and C-3 *pro-R* positions.

Synthesis of (2S)-Argininosuccinate-2-d (IV) and (2S,3S)-Argininosuccinate-3-d (V) (Chart I). These molecules were synthesized by the combined activities of argininosuccinate synthetase, aspartase, and aspartate aminotransferase. (2S)-Aspartate-2-*d* was synthesized from aspartate and D₂O in the presence of aspartate aminotransferase. Aspartate (500 mg) was incubated in a 50-mL solution of D₂O containing 100 mM phosphate buffer, pD 7.5, 0.5 mg of pyridoxal phosphate, 0.1 mM α -ketoglutarate, and 1 drop of toluene. The reaction was initiated by adding 1000 units of aspartate aminotransferase. The exchange of the proton at C-2 of aspartate was monitored by proton NMR spectroscopy at 90 MHz. The reaction was quenched after 5 h by heating the solution at 75 °C for 10 min. The (2S)-aspartate-2-*d* was used without further purification. (2S)-Argininosuccinate-2-*d* was then synthesized by the reaction catalyzed by argininosuccinate synthetase. The reaction mixture contained 50 mM Tris¹ buffer, pH 7.5, 7.5 mM citrulline, 7.5 mM ATP, 10 mM MgCl₂, 5 mM (2S)-aspartate-2-*d*, and 10 units of inorganic pyrophosphatase. The reaction was initiated by the addition of the argininosuccinate synthetase. (2S)-Argininosuccinate-2-*d* was isolated as the barium salt according to the method described by Ratner et al. (1953). The overall yield was 43%. The incorporation of deuterium at C-2 was 76%.

(2S,3S)-Argininosuccinate-3-*d* was synthesized by a similar procedure. (2S,3S)-Aspartate-2,3-*d*₂ was made by the reverse reaction of aspartase according to the method by Nuiry et al. (1984). The deuterium at C-2 was exchanged for a proton by the addition of aspartate aminotransferase in H₂O. The (2S,3S)-aspartate-3-*d* was then converted to (2S,3S)-argi-

nosuccinate-3-*d* by the action of argininosuccinate synthetase. The deuterium incorporation at the *pro-S* position at C-3 was 80%. The incorporation of hydrogen at C-2 was 90%. The structures of the five deuterated molecules are shown in Chart I.

Determination of Deuterium Isotope Effects by Direct Comparison. The deuterium isotope effects on V_{\max} and V/K were obtained by comparing the intercepts and the slopes of the double-reciprocal plots ($1/v$ vs. $1/[S]$) of the unlabeled argininosuccinate with the various deuterium-labeled compounds. The extinction coefficients used for fumarate, fumarate-*d*, and fumarate-2,3-*d*₂ at 240 nm were 2.25 mM⁻¹ cm⁻¹, 2.23 mM⁻¹ cm⁻¹, and 2.21 mM⁻¹ cm⁻¹, respectively (Cook et al., 1980). All of the data were collected on a Gilford 2600 spectrophotometer with a Hewlett-Packard plotter to record the time course of the reaction. The temperature was maintained at 25 °C with thermospacers and a circulating water bath. All reaction mixtures contained 50 mM Tris buffer, 100 mM KCl, pH 8.0, argininosuccinate, and argininosuccinate lyase in a volume of 3 mL. The data were fit to eq 1 to obtain the isotope effects on V_{\max} and V/K . In eq

$$v = VA/[K(1 + F_i E_{v/k}) + A(1 + F_i E_v)] \quad (1)$$

1, F_i is the fraction of isotopic substitution and E_v and $E_{v/k}$ are the isotope effects minus 1 on V and V/K .

Deuterium Isotope Effects on Equilibrium Constants. The deuterium isotope effects on the equilibrium constant for the argininosuccinate lyase reaction were measured. Reaction mixtures contained 0.52 mM fumarate or fumarate-2,3-*d*₂, 50 mM Tris buffer, pH 8.0, 100 mM KCl, and various amounts of arginine. The reaction was initiated by adding argininosuccinate lyase. After equilibrium was reached, the change in the fumarate concentration was plotted vs. the initial concentration of arginine. From this plot, the concentration of arginine that caused the initial fumarate concentration to be reduced by exactly half was obtained. This concentration of arginine (after subtraction of the amount that was converted to argininosuccinate) is equivalent to the equilibrium constant for the argininosuccinate lyase reaction.

The equilibrium constant for the monodeuterated argininosuccinate was measured in a similar manner. The reaction mixtures contained 0.530 mM (2S)-argininosuccinate-3-*d*, 50 mM Tris buffer, pH 8.0, 100 mM KCl, and variable amounts of arginine. The equilibrium constant was calculated as the final concentration of arginine that caused exactly half of the original argininosuccinate to be converted to products.

Deuterium Isotope Effects by Equilibrium Perturbation. The deuterium isotope effects on V/K were measured by the equilibrium perturbation technique of Schimerlik et al. (1975). Reaction mixtures contained in a volume of 3.0 mL 50 mM Tris, pH 8.0, 100 mM KCl, and various amounts of argininosuccinate, fumarate, and arginine. Either the argininosuccinate or the fumarate contained the deuterium label. The concentrations of substrates and products were chosen to exactly match the equilibrium constant for the reaction. The reaction was initiated by the addition of 50 μ L of argininosuccinate lyase. The change in the concentration of fumarate was followed at 240 nm, and the maximum perturbation was measured. The isotope effects on V/K were calculated with a computer program written by Cleland (1977).

¹⁵K_{eq} Isotope Effects and ¹⁵(V/K) Isotope Effects. The ¹⁵K_{eq} isotope effects were determined by an isotope ratio mass spectral analysis of the guanidino amino nitrogens of arginine at the beginning of the reaction and after the argininosuccinate lyase reaction had attained isotopic equilibrium. The reaction mixture contained 50 mM phosphate buffer, pH 8.0, 10 mM

¹ Abbreviation: Tris, tris(hydroxymethyl)aminomethane.

arginine, 10 mM fumarate, and argininosuccinate lyase in a volume of 60 mL. After the reaction had reached equilibrium, the reaction was quenched by lowering the pH to 2.5 with 50% trichloroacetic acid to denature the argininosuccinate lyase. After centrifugation, the pH was raised to 8.0, and 1000 units of arginase was added to convert all of the arginine to urea and ornithine. The ornithine was removed by passage of the reaction solution through a 10-mL ion-exchange column of Dowex 50 (Na⁺) resin. The isolated urea was converted to NH₃ and CO₂ by the addition of 1000 units of urease. After the reaction was quenched with 10 mL of 13 M NaOH, the NH₃ was collected by steam distillation (Bremner, 1965) into a 10-mL solution of 0.5 N H₂SO₄. The concentration of NH₄⁺ was assayed by using glutamate dehydrogenase. The yield was quantitative for the conversion from arginine to NH₄⁺. NH₄⁺ was obtained from the initial arginine by the same method. The NH₄⁺ was converted to N₂ by the addition of hypobromite, and the ratio of ¹⁵N/¹⁴N was analyzed by a Varian MAT 250 dual-inlet isotope ratio mass spectrometer (Hermes et al., 1985). ¹⁵N equilibrium isotope effects were calculated from (Hermes et al., 1985)

$$^{15}K_{\text{eq}} = y_2/y_1 + x_1(y_2/y_1 - 1) \quad (2)$$

where x_1 is the [product]/[reactant] ratio at equilibrium, y_1 is the ¹⁵N/¹⁴N ratio of the product at equilibrium, and y_2 is the mass ratio of the initial reactant.

The ¹⁵(V/K) isotope effects on the argininosuccinate lyase reaction were determined by an isotope ratio mass spectral analysis of the guanidino amino nitrogens in arginine at 100% and 12% conversion of argininosuccinate to products. The reaction mixture contained in a volume of 120 mL 50 mM phosphate buffer, pH 8.0, 10 mM argininosuccinate, and 1750 units of arginase. The reaction was initiated by adding argininosuccinate lyase. The absorbance was monitored at 280 nm to determine the extent of the reaction. When the reaction reached 12% completion, a 90-mL aliquot was removed and quenched with trichloroacetic acid. The rest of the reaction mixture was incubated overnight in order that the reaction could be completed. The urea in both samples was converted to NH₃ and analyzed as N₂ by the procedure described above. The yield was quantitative. The value of ¹⁵(V/K) was calculated from

$$^{15}(V/K) = \frac{\log(1-f)}{\log(1-fR/R_0)} \quad (3)$$

where R is the ¹⁵N/¹⁴N ratio in the product at the fraction of the reaction f and R_0 is the ¹⁵N/¹⁴N ratio in the initial substrate.

Nonequilibrium Isotope Exchange of Solvent Protons with Argininosuccinate. The rate of exchange of solvent protons into the *pro-R* position at C-3 of argininosuccinate was measured during net catalysis of the forward reaction. The reaction mixture contained 50 mM phosphate buffer, pH 8.0, 10 mM (3*R*)-argininosuccinate-3-*d*, 500 units of arginase, argininosuccinate lyase, and various amounts of added fumarate in a volume of 10 mL. The reaction was quenched with 50% trichloroacetic acid when the concentration of the initial argininosuccinate was reduced by approximately 50%. After centrifugation, the pH was raised to 7.5. This solution was evaporated to dryness, 1 mL of D₂O was added, and the solution was evaporated again. This procedure was then repeated. The dried product was dissolved in 1 mL of D₂O. The rate of conversion of argininosuccinate to products was determined by integration of the NMR signals for the remaining argininosuccinate and ornithine. The rate of proton exchange

was determined by comparison of the integrals for the *pro-R* and *pro-S* protons of C-3 in the argininosuccinate. The ratio of the rate for the exchange reaction to that for the net conversion to products was obtained from

$$v_{\text{ex}}/v_{\text{conv}} = \log(1-F)/\log(1-X) \quad (4)$$

where X is the fraction of change of the original argininosuccinate at time t and F is the fraction of the equilibrium value for the exchange reaction at time t (Litwin & Wimmer, 1979).

Equilibrium Isotope Exchange Reactions. The rate of isotopic exchange of solvent protons and fumarate with argininosuccinate at chemical equilibrium was measured. The reaction mixture contained 3.02 mM (2*S*)-argininosuccinate-2,3,3-*d*₃, 3.02 mM fumarate, 3.02 mM arginine, 50 mM phosphate buffer, pH 8.0, and argininosuccinate lyase in a volume of 300 mL. At various times, 50-mL aliquots were removed and quenched with trichloroacetic acid. The samples were processed as described above. The rate of exchange of a proton for deuterium at the *pro-R* position at C-3 of argininosuccinate was determined by integration of the signal at 2.65 ppm. The rate of exchange for fumarate with argininosuccinate was made by integration of the proton NMR spectrum of the signals for the hydrogen at C-2 and the *pro-S* position at C-3 of argininosuccinate at 4.08 and 2.38 ppm. The rates of the exchange reactions were obtained according to

$$v_{\text{ex}}(\text{hydrogen}) = A_0 \ln(1-F)/t \quad (5)$$

$$v_{\text{ex}}(\text{fumarate}) = A_0 P_0 \ln(1-F)/[(A_0 + P_0)t] \quad (6)$$

where A_0 is the initial concentration of argininosuccinate, P_0 is that of fumarate, and F is the fraction of the equilibrium value for the exchange reaction at time t .

Solvent Deuterium Isotope Effects. The solvent deuterium isotope effects on V_{max} were determined by comparison of the enzyme-catalyzed rates in H₂O and D₂O at saturating argininosuccinate. The buffer solutions in H₂O and D₂O were titrated to an identical pH meter reading of 8.0 (pD 8.4). The higher pD of the solutions in D₂O partially compensates for the shift in the pH-rate profile in D₂O. The V_{max} pH-rate profile for the cleavage of argininosuccinate in H₂O shows a single group with a pK of 6.7 that must be unprotonated for maximal activity (Garrard et al., 1985). In D₂O, this pK is increased by 0.6 pK unit (F. M. Raushel, unpublished observations).

Enzyme Assay. Enzyme assays and absorbance measurements were made with a Gilford 2600 UV-VIS spectrophotometer and a Hewlett-Packard 7225A plotter. A unit of argininosuccinate lyase is defined as the amount of enzyme needed to catalyze the formation of 1 μmol of fumarate/min at 25 °C and pH 7.5 at saturating argininosuccinate (Raushel & Nygaard, 1983).

RESULTS

Deuterium Isotope Effects. The primary and secondary deuterium isotope effects on V_{max} and V/K were measured with (2*S*)-argininosuccinate-2-*d*, (2*S*,3*R*)-argininosuccinate-3-*d*, (2*S*,3*S*)-argininosuccinate-3-*d*, and (2*S*)-argininosuccinate-2,3-*d*₂ by the direct comparison of the initial velocities with unlabeled argininosuccinate at pH 8.0. The results are tabulated in Table I. These same compounds and fumarate-*d*₂ were also used to measure the V/K isotope effects by the isotope perturbation technique of Schimerlik et al. (1975). The results are listed in Table I. The V/K isotope effect for fumarate-*d*₂ was also measured by the isotope perturbation technique as a function of the concentration of added arginine and argininosuccinate. The observed isotope effect with fu-

Scheme I

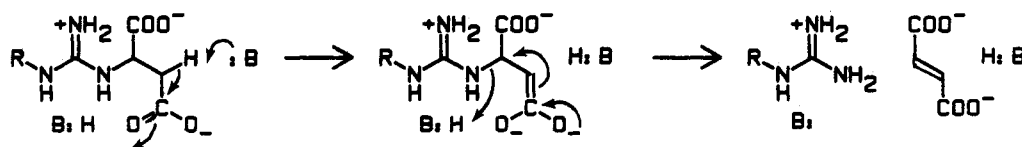

Table I: Deuterium Isotope Effects at pH 8.0, 25 °C

compd	D_V	$D(V/K)$	$D(\text{eq P})$
(2 <i>S</i> ,3 <i>R</i>)-argininosuccinate-3- <i>d</i>	0.97 ± 0.06	1.03 ± 0.03	
(2 <i>S</i> ,3 <i>S</i>)-argininosuccinate-3- <i>d</i>	1.00 ± 0.05	1.15 ± 0.05	1.16 ± 0.02
(2 <i>S</i>)-argininosuccinate-2- <i>d</i>	1.12 ± 0.05	1.14 ± 0.04	1.19 ± 0.02
(2 <i>S</i> ,3 <i>S</i>)-argininosuccinate-2,3- <i>d</i> ₂	1.15 ± 0.02	1.12 ± 0.02	1.18 ± 0.02
fumarate-2,3- <i>d</i> ₂			0.87 ± 0.02

marate-*d*₂ was found to be constant (0.87 ± 0.02) when the arginine concentration was varied from 1.0 to 40 mM. The isotope effects on the equilibrium constant, defined as ${}^H K_{\text{eq}}/{}^D K_{\text{eq}}$, were found to be 1.34 ± 0.03 , 1.15 ± 0.02 , and 1.15 ± 0.02 for (2*S*,3*S*)-argininosuccinate-2,3-*d*₂, (2*S*,3*S*)-argininosuccinate-3-*d*, and (2*S*)-argininosuccinate-2-*d*, respectively. The calculated isotope effects on the equilibrium constants,² with the rules of Schimerlik et al. (1975), are 1.38, 1.18, and 1.18.

Nitrogen-15 Isotope Effects. The effect of nitrogen-15 substitution at the guanidino amino groups on the reaction rate was measured by analyzing the ${}^{15}\text{N}/{}^{14}\text{N}$ ratio of the product at low conversion and again at complete conversion (Hermes et al., 1985). The ${}^{15}\text{N}/{}^{14}\text{N}$ ratio of the two guanidino amino groups of arginine was determined by the enzymatic transformation to NH_4^+ by the action of arginase and urease. The ammonia was then converted to N_2 with hypobromite, and the isotope ratio was measured with an isotope ratio mass spectrometer. The ${}^{15}(V/K)$ isotope effect for conversion of argininosuccinate to products was found to be 0.9964 ± 0.0003 from an average of 16 determinations. The value for the effect on the equilibrium constant, ${}^{15}K_{\text{eq}}$, was found to be 1.018 ± 0.001 .

Argininosuccinate-Solvent Exchange Reactions. The exchange of a solvent proton into the *pro-R* position at C-3 of argininosuccinate was measured during catalysis of the net forward reaction by argininosuccinate lyase. Excess arginase was added to make the conversion of argininosuccinate to products irreversible. (2*S*,3*R*)-Argininosuccinate-3-*d* was used as the substrate in order that the incorporation of protons from the solvent could be followed by NMR. No exchange of protons from the solvent (<5%) was detected when the initial fumarate concentration was zero. Significant exchange could be detected when the initial concentration of fumarate was increased from zero to 60 mM. The ratio of the exchange reaction and the chemical reaction ($v_{\text{ex}}/v_{\text{chem}}$) as a function of the initial concentration of fumarate is plotted in Figure 1. The data were fit to the HYPERO program of Cleland (1979). The maximal exchange ratio at saturating fumarate is 2.8 ± 0.4 , and the concentration of fumarate that produces

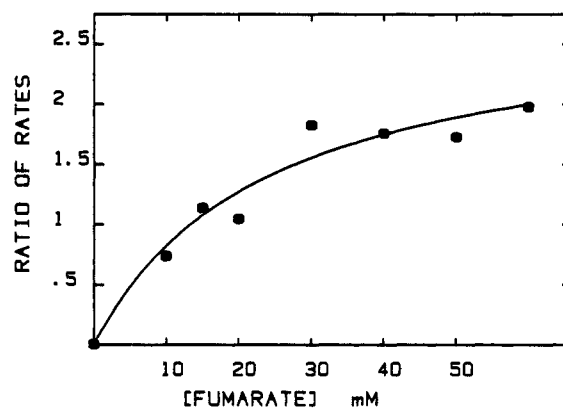

FIGURE 1: Plot of ratio of rate of solvent-argininosuccinate exchange and rate of net substrate turnover as a function of added fumarate. The solid line is a fit to the Michaelis-Menten equation where the maximal ratio is 2.8 and the concentration of fumarate that produces half of the maximal effect is 24 mM.

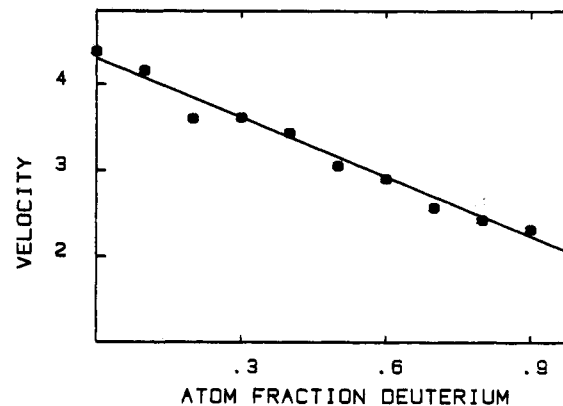

FIGURE 2: Proton inventory experiment for the solvent isotope effect on V_{max} for the argininosuccinate lyase reaction.

half of the maximal effect, K_p^* , is 24 ± 9 mM.

The rates of exchange of solvent protons and fumarate with argininosuccinate were measured at chemical equilibrium. At pH 8.0 and 25 °C, the ratio of the solvent exchange rate and the fumarate exchange rate was found to be 1.2 ± 0.2 .

Solvent Isotope Effects. The effect of D_2O on the rate of cleavage of argininosuccinate to arginine and fumarate was measured at pH 8.0. The solvent isotope effect on V_{max} is 2.0 ± 0.1 . A proton inventory experiment (Schowen, 1977) for the effect on V_{max} is illustrated in Figure 2.

DISCUSSION

Chemical Mechanism. A plausible chemical mechanism for the conversion of argininosuccinate to arginine and fumaric acid is presented in Scheme I. In this mechanism, an enzyme base abstracts the *pro-R* proton of C-3 to initially form a carbanion intermediate that is stabilized in the aci configuration. In the subsequent step, the carbon-nitrogen bond at C-2 is broken while the guanidino nitrogen is protonated by an acidic group of the protein to form the enzyme-bound products. The formation of the carbanion intermediate is supported by the observation that the ionized form of the nitro analogue of argininosuccinate binds at least 25 times tighter

² The predicted value for (2*S*,3*S*)-argininosuccinate-2,3-*d*₂ is the product of the square of the effect for changing hybridization from sp^3 to sp^2 (1.11) and that for replacing a hydrogen with an uncharged nitrogen at C-2 (1.12) (Cook et al., 1980). The predicted values for (2*S*,3*S*)-argininosuccinate-3-*d* and (2*S*)-argininosuccinate-2-*d* are identical because of the scrambling of the deuterium between C-2 and C-3 via monodeuteriofumarate. This value should be equal to the average of the effect at C-3 (1.11) and C-2 ($1.11 \times 1.12 = 1.24$).

than does argininosuccinate itself (Rauschel, 1984). Porter and Bright (1980) have argued that the nitronate configuration of this type of inhibitor is mimicking the carbanion intermediate in the aci configuration. Moreover, two other related enzymes, aspartase and phenylalanine ammonia-lyase, have also been shown to catalyze the elimination of ammonia via a carbanion intermediate. The participation of the general acid and general base groups in catalysis is consistent with the pH profiles of enzymatic activity. These profiles have shown that an unprotonated and a protonated group are required for catalytic activity (Garrard et al., 1985). These groups have tentatively been identified as a carboxylate and imidazole side chains on the basis of inactivation experiments (Garrard et al., 1985). The mechanistic features of this reaction have now been further probed by the introduction of isotopic labels at the points of bond cleavage.

Proton Abstraction. When the proton at the *pro-R* position of C-3 is replaced by a deuterium, there is no observable effect on either V_{\max} or V/K . Therefore, the abstraction of this proton is not significantly rate determining for the overall reaction. Furthermore, this proton, once abstracted from argininosuccinate, does not appear to exchange with solvent during net catalysis of the forward reaction. Thus, this proton must be shielded from the solvent in the intermediate complex.

The proton that is abstracted from C-3 can exchange with solvent once the E-arginine-fumarate complex is formed. This has been clearly demonstrated in the experiment where fumarate has been used to inhibit the forward reaction and an exchange reaction was observed from the solvent back into argininosuccinate (Figure 1). The presence of a large excess of arginase in this experiment prevented arginine from reassociating with the enzyme once it is released into solution. Therefore, the proton that is abstracted from C-3 must be exchanging with solvent before arginine is released into solution. Otherwise, exchange back into argininosuccinate would not be possible. Since there is no diminution of the exchange rate at high levels of fumarate, the abstracted proton also must be able to exchange with solvent from the enzyme-fumarate-arginine complex.

The rate of solvent exchange back into the original argininosuccinate pool during net formation of products is identical with the previously determined rate of labeled-fumarate exchange back into argininosuccinate (Kim & Rauschel, 1986). Furthermore, both of these exchange reaction rates are nearly identical with the rate of positional isotope exchange of ^{15}N -labeled argininosuccinate (Rauschel & Garrard, 1983). These results clearly indicate that the exchange of the proton from the enzyme-arginine-fumarate complex is very fast. At low fumarate, no backexchange is observed because of the very rapid release of fumarate into solution. At saturating fumarate, the ratio of the exchange rate and the chemical rate is governed by the rate of release of arginine from the enzyme-arginine-fumarate complex. It can thus be concluded that both the C-3-derived proton and fumarate are rapidly released into solution from the enzyme-fumarate-arginine complex while arginine is only slowly released (relative to V_{\max} in the reverse direction). The nearly identical isotopic exchange rates of fumarate and solvent with argininosuccinate at chemical equilibrium support this conclusion.

Carbon-Nitrogen Bond Breakage. The measured isotope effect on V/K for the substitution of ^{15}N at the guanidino position is slightly inverse. The observed effect cannot be due solely to carbon-nitrogen bond cleavage since kinetic effects on bond breaking are always positive for the heavier isotope. The inverse effect cannot be an expression of the equilibrium

isotope effect for the overall reaction since that effect has been measured and is also normal. However, an inverse equilibrium isotope effect is expected for the protonation of the guanidino nitrogen. For example, the measured ^{15}N equilibrium isotope effect for the protonation of NH_3 and phenylalanine is 0.981 and 0.983, respectively (Hermes et al., 1985). This inverse effect is due directly to the stiffer bonding upon protonation. Thus, if the inverse effect for the protonation of the guanidino nitrogen is slightly larger than the normal kinetic effect for bond breaking, the resultant effect would be slightly inverse.³ If the protonation of the guanidino group is in equilibrium in the steady state, then the rate-limiting step in the reaction mechanism must follow. Since the release of both products is very fast, the major rate limitation to this reaction must either be the cleavage of the carbon-nitrogen bond or an associated protein conformational change.

The ^{15}N isotope effect has been measured for the reaction catalyzed by aspartase (Nuiry et al., 1984). The kinetic effect of 1.0239 was significantly larger than the equilibrium effect of 1.0138 for the deamination of aspartate to fumarate (Hermes et al., 1985). Therefore, in the aspartase reaction, C-N bond cleavage is largely rate determining for the overall reaction. The protonation of the nitrogen is unimportant in the aspartase reaction because the aspartate monoanion is the actual substrate and free ammonia is the product and thus a protonation step is not necessary. Enzyme-directed protonation is presumably required in the argininosuccinate lyase reaction because the guanidino group of arginine is at least 1000 times more basic than ammonia.

Secondary Isotope Effects. The negligible primary isotope effects on V_{\max} and V/K for (2*S*,3*R*)-argininosuccinate-3-*d* compared to the probable intrinsic isotope effect of 5-7 for the C-H bond cleavage step suggest that the sum of the commitments for this step is large (Cook & Cleland, 1981). Therefore, the observed α -secondary effect of 1.15 on V/K for deuterium substitution at the *pro-S* position of C-3 must represent an equilibrium isotope effect on the formation of the carbanion intermediate. The formation of the stabilized intermediate in the aci configuration requires a change in hybridization at C-3 from sp^3 to sp^2 . An equilibrium isotope effect of this type would be expected to be approximately 1.11 (Cook et al., 1980). The size of the observed α -secondary isotope effect at C-3 on V/K (1.15) indicates that a full equilibrium effect is being observed and suggests that carbanion formation is in equilibrium in the steady state. The observed α -secondary effect on V_{\max} is smaller. Apparently, the ratio of the forward and reverse commitments in the expression for the isotope effect on V_{\max} is such that the equilibrium isotope effect is suppressed (Cook et al., 1981).

The observed α -secondary effect on V_{\max} and V/K caused by the substitution of deuterium at C-2 is 1.12 and 1.14, respectively. The calculated equilibrium isotope effect of 1.25 for this substitution is due to a change in hybridization from sp^3 to sp^2 (1.11) times the effect for replacement of a hydrogen with an uncharged nitrogen (1.12) (Cook et al., 1980). The substitution of deuterium at C-2 will only affect the step in the proposed mechanism that involves the transformation of the carbanion intermediate to arginine and fumarate. If this step is at least partially or totally rate limiting for the overall reaction, then the observed α -secondary isotope effect at C-2 would be a kinetic effect that is approximately half of the

³ The steps for the protonation of the guanidino nitrogen and carbon-nitrogen bond cleavage have been considered as occurring simultaneously or nearly so. A mechanism where the protonation step precedes C-N bond breakage must also be considered as probable.

maximal possible value. This is not unreasonable since it has already been demonstrated that the steps for proton abstraction from C-3 and product release are fast relative to the rate of the overall reaction.

The secondary isotope effect for the reaction of fumarate- d_2 is inverse (0.87). The inverse effect is expected because of the preference of deuterium for the stiffer sp^3 -hybridized bonds of argininosuccinate. The calculated equilibrium effect of 0.72 is in reasonable agreement with the experimental value of 0.75. The analysis of the α -secondary effects for fumarate- d_2 is complicated because the deuterium substitution in fumarate- d_2 can affect both steps in the mechanism. However, if the rate-limiting step in the reverse reaction of argininosuccinate lyase is primarily the addition of the guanidino nitrogen of arginine to fumarate to form the carbanion intermediate, then the simplest interpretation of the fumarate- d_2 isotope effects is that they reflect the hybridization change at C-2 only. The magnitude of the α -deuterium isotope effect for fumarate- d_2 is not influenced by the concentration of arginine in the reaction mixture. This indicates that arginine cannot trap fumarate on the enzyme (Cook & Cleland, 1981). This result is consistent with the random kinetic mechanism for this enzyme (Raushel & Nygaard, 1983; Raushel & Garrard, 1984).

Summary. The abstraction of the proton from C-3 of argininosuccinate is not at all rate determining in the reaction catalyzed by argininosuccinate lyase. The proton derived from C-3 of argininosuccinate is able to rapidly exchange with solvent from the enzyme-arginine-fumarate complex. Nitrogen-15 and solvent deuterium isotope effects have indicated that protonation of the guanidino group and C-N bond breakage are kinetically important for the overall rate.

ACKNOWLEDGMENTS

We thank Chandra Ghose for the purification of argininosuccinate synthetase. We also thank Paul Weiss for the analysis of the $^{15}\text{N}/^{14}\text{N}$ ratios and W. W. Cleland for helpful discussions.

REFERENCES

Bremner, J. M. (1965) *Methods of Soil Analysis* (Black, C. A., Ed.) Part 2, pp 1256-1286, American Society of Agronomy, Madison, WI.

Cleland, W. W. (1980) *Methods Enzymol.* 64, 104-125.
Cook, P. F., & Cleland, W. W. (1981) *Biochemistry* 20, 1790-1796.
Cook, P. F., Blanchard, J. S., & Cleland, W. W. (1980) *Biochemistry* 19, 4853-4858.
Cook, P. F., Oppenheimer, N. J., & Cleland, W. W. (1981) *Biochemistry* 20, 1817-1825.
Garrard, L. J., Mathis, J. M., & Raushel, F. M. (1983) *Biochemistry* 22, 3729-3735.
Garrard, L. J., Que, T. N. B., Nygaard, R., & Raushel, F. M. (1985) *J. Biol. Chem.* 260, 5548-5553.
Havir, E. A., Tamir, H., Ratner, S., & Warner, R. D. (1965) *J. Biol. Chem.* 240, 3079-3088.
Hermes, J. D., Weiss, P. M., & Cleland, W. W. (1985) *Biochemistry* 24, 2959-2967.
Kim, S. C., & Raushel, F. M. (1986) *J. Biol. Chem.* 261, 8163-8166.
Litwin, S., & Wimmer, M. J. (1979) *J. Biol. Chem.* 254, 1859.
Lusty, C. J., & Ratner, S. (1972) *J. Biol. Chem.* 247, 7010-7022.
Nuiry, I. I., Hermes, J. D., Weiss, P. M., Chen, C., & Cook, P. F. (1984) *Biochemistry* 23, 5168-5175.
Porter, D. J. T., & Bright, H. J. (1980) *J. Biol. Chem.* 255, 4772-4780.
Ratner, S., Anslow, W. P., & Petrack, B. (1953) *J. Biol. Chem.* 204, 115-125.
Raushel, F. M. (1984) *Arch. Biochem. Biophys.* 232, 520-525.
Raushel, F. M., & Nygaard, R. (1983) *Arch. Biochem. Biophys.* 221, 143-147.
Raushel, F. M., & Garrard, L. J. (1984) *Biochemistry* 23, 1791-1795.
Rochovansky, O., & Ratner, S. (1977) *J. Biol. Chem.* 252, 5287-5294.
Schimerlik, M. I., Rife, J. E., & Cleland, W. W. (1975) *Biochemistry* 14, 5347-5354.
Schowen, R. L. (1977) in *Isotope Effects in Enzyme-Catalyzed Reactions* (Cleland, W. W., O'Leary, M. H., & Northrop, D. B., Eds.) p 64, University Park Press, Baltimore, MD.
Schulze, I. T., Lusty, C. J., & Ratner, S. (1970) *J. Biol. Chem.* 245, 4534-4543.